

# LAUFEN

Bathroom Culture since 1892  [www.laufen.com](http://www.laufen.com)



GENERAL CATALOGUE  
2016/17



ILBAGNOALESSI ONE page 16



ILBAGNOALESSI DOT page 28



PALOMBA COLLECTION page 30



KARTELL BY LAUFEN page 40



LIVING page 52



LB3 page 66



INO page 70



VAL page 76



PALACE page 84



LAUFEN PRO page 90

# CONTENTS

## **ABOUT US**

02	THE LAUFEN COMPANY
04	THE HERITAGE OF LAUFEN
05	THE LAUFEN FORUM
06	SAPHIRKERAMIK
08	OUTSTANDING DESIGN
09	THE DESIGNERS
10	THE PRODUCTION
11	SUSTAINABLE QUALITY
12	THE REFERENCES – PUBLIC BUILDINGS
14	THE REFERENCES – HOTELS
15	THE REFERENCES – RESIDENTIAL BUILDINGS

## **DESIGNLINE**

16	ILBAGNOALESSI ONE
28	ILBAGNOALESSI DOT
30	PALOMBA COLLECTION
40	KARTELL BY LAUFEN
52	LIVING
66	LB <sup>3</sup>
70	INO
76	VAL
84	PALACE
90	LAUFEN PRO

## **WASHBASINS**

108	WASHBASIN BOWLS
110	WASHBASINS, UNDERSURFACE GROUND
111	SEMI-RECESSED WASHBASINS
112	DROP-IN WASHBASINS
114	BUILT-IN WASHBASINS

## **SPECIAL APPLICATIONS**

116	HIJET WC
118	ONE PIECE TOILETS

## **BATHROOM FURNITURE**

122	WHAT GOES WITH WHAT?
123	OVERVIEW OF FURNITURE COLOURS
124	CASE
128	SPACE
132	BOUTIQUE

## **FAUCETS**

140	KARTELL BY LAUFEN
-----	-------------------

## **ACCESSORIES**

141	CERAMIC SHELVES AND ACCESSORIES
-----	---------------------------------

## **APPENDIX**

142	PRODUCT FEATURES AND BENEFITS
150	CERAMIC COLOURS AND OPTIONS

# THE COMPANY

LAUFEN stands for swissness, quality and design, offering complete bathroom solutions around the world.

## LAUFEN IN FIGURES

Laufen Bathrooms AG is a Swiss company specialised on premium segment solutions for bathrooms. The headquartes are located in Laufen near Basel. Managed by the family-owned Roca group since 1999 Laufen runs 7 manufacturing sites in Central Europe, 2500 employees and sales offices in 44 countries.



1 Palomba Collection, 2012  
2 Living SaphirKeramik, 2013

**MAKING THE BATHROOM  
A LIVING ENVIRONMENT**

The personality of this highly traditional Swiss brand reflects a symbiosis of design, quality and functionality. LAUFEN, the premium brand under the ROCA umbrella, is one of the world's leading manufacturers with a global distribution network. The company's core competence is its knowledge in the area of sanitary ware manufacturing. Over 120 years, the LAUFEN brand has been using the oldest malleable material known to man to make innovative sanitary products in state-of-the-art plants with legendary Swiss precision. Knowledge of the bathroom as a whole developed from the competence of LAUFEN in ceramics manufacturing, and sophisticated design. What makes LAUFEN products unique at the first glance is that their Swiss design unites two major design trends: emotional Italian design from the south and the northern tradition of design precision and clarity. For LAUFEN, quality has two aspects: manufacturing knowledge and high degree of practical benefit that the finished bathroom affords the customer – which is often not immediately apparent. LAUFEN, a Swiss company manufacturing products that allow water, a precious resource, to be used sparingly, demonstrates in this manner a commitment to preserving natural resources and environmentally-friendly production.



1 The first one-piece, floorstanding washbasin  
ILBAGNOLESSI One, 2001  
2 LAUFEN headquarters with Forum, ceramic and  
faucet factory, training and logistic centre

**FROM HUMBLE BEGINNINGS TO TODAY'S GLOBAL PLAYER**

When Laufen was founded in Switzerland in 1892, sanitation was still a far cry from the standards and comforts offered today; standards, which were particularly influenced by Laufen, the only sanitary ceramics producer that manufactures exclusively in Europe.

Some of the production facilities that belong to the company today can be traced back even further into history. In 1878 for example, the pioneer in the mechanical manufacture of sanitary ceramics was a production site belonging to the Austrian monarchy.

It is not just tradition, but also the strong anchor the various European manufacturing sites maintain in their domestic markets, Switzerland, Austria and Czech Republic, that underpin the quality of Laufen as a company. Laufen's goal then was the same as today's: to lead on technology, service and design. Back in the 1980s, Laufen engineers invented the most efficient high-pressure casting technology for ceramic production and therefore ensured a sustainable breakthrough in industrial production.

Just as important at Laufen are the constant developments in design: wall-mounted WCs and floor-standing washbasins have enabled a new sense of aesthetics. In 2013 Laufen's world wide material innovation SaphirKeramik succeeded in revolutionising the design language of ceramic.

The innovative and valuable SaphirKeramik formulation gives the starting material unprecedented possibilities and scopes. SaphirKeramik is used when a design includes thin walled shapes and tight radii.

Laufen has extended its expertise and its portfolio of ceramic products, bathtubs, furniture and accessories to include faucets. In 1854 Charles Kugler founded a small company for brass products in Lausanne. The first water and gas fittings on Swiss soil were made there in 1863. Since 2009 faucets have been produced at the newly built factory in Laufen.

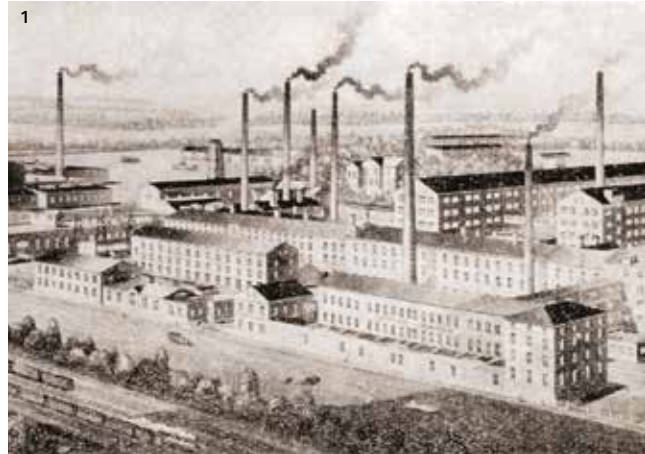

1 First mechanical factory for sanitary ware on the European continent, Znojmo  
 2 SaphirKeramik a new formulation revolutions the design language of ceramic, January 2013  
 3 Invention of the wall hung toilet by Laufen engineer Xaver Jermann, 1964

## A BUILDING OF GREAT SYMBOLIC VALUE

Laufen is synonymous with perfection in terms of form and craftsmanship and for advanced technology with an unobtrusive face. LAUFEN's headquarters in the Baseland canton reflect this identity. Ludovica and Roberto Palomba designed "bowl/08", a wash-basin for the Palomba Collection.

Architects Nissen & Wentzlaff created a larger version of this object in the form of the building which stands out with its impressive exposed concrete and elegant statics.

An inventive spirit and desire for technical innovation are also part of the building's concept and (just like the manufacture of LAUFEN's products) require efficient resource usage and an acceptable ecological footprint. As a result, the multi-award-winning building is an outstanding feature in the Basel area which is rich in superb architecture.

With the Forum, LAUFEN has created a new architectural setting for its products: it is a comprehensive architectural statement in concrete with the bathroom at its centre and acknowledges Switzerland unequivocally as the company's headquarters and production site. A space for the bathroom with the power to inspire clients, architects, retailers and tradesmen alike and provide a source of information.

This is also the home of the training centre of LAUFEN Bathrooms AG. A wide range of seminars is held here to train groups and communicate product knowledge. Training sessions also take place in the Sky Gallery in Wilhelmsburg, Austria, and in Znojmo in the Czech Republic.

LAUFEN won the "Award for Marketing + Architecture" in the category "Office and commercial buildings - industrial and commercial interiors" in 2010. It also won the Green Good Design Award and, in 2011, the "best architects award 2011" in the category "Business and Industrial Buildings".



1 The Canton of Baseland between the Doubs and the Rhine River.  
 3 The LAUFEN Forum - flagship showroom as a platform for dialogue.  
 2 The LAUFEN Forum is a 6,500 cubic metre architectural statement, a visitor and presentation centre designed by Basel based architects Nissen & Wentzlaff, photographed by Maurizio Marcato.



## A REVOLUTION IN CERAMIC

Launched in 2013, Saphirkeramik is pioneering Swiss company LAUFEN's latest innovation. This revolutionary, ceramic material reaches its exceptional hardness blended with corundum, a colourless mineral, which is a component of sapphires. This gives SaphirKeramik a flexural strength equal to that of steel. Yet it has the potential to be wafer-thin, giving designers almost infinite freedom to experiment – and tear up the rulebook of bathroom design. With over two years' experience of producing SaphirKeramik pieces on an industrial scale, LAUFEN is now stretching the patent-pending material's limits by exploiting its super-fine forms not only to create exquisitely detailed textures and patterns but also by engineering the innovative material to increase its maximum size – a 120 cm-long washbasin in SaphirKeramik is the largest to date. LAUFEN has also applied its impressively efficient, high-pressure casting technology to other, high-volume pieces in SaphirKeramik. In collaboration with cutting-edge designers Konstantin Grcic and Toan Nguyen, LAUFEN unveiled design prototyping at such prestigious design events as the Milan Furniture Fair, Art Basel / Design Miami and London Design Festival 2014. Visitors appreciated the wondrous qualities of ceramic – its tactile appeal, luminosity and enduringly spotless surface – and SaphirKeramik's bewitchingly thin and robust walls.

### SaphirKeramik



### Proven sanitaryware



## SaphirKeramik

### BENDING STRENGTH

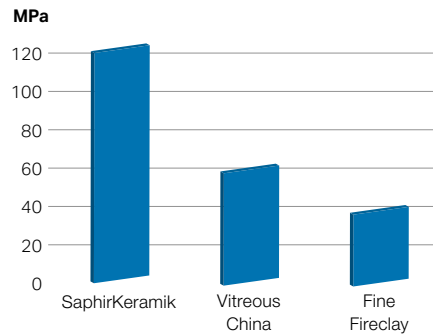

Source: Bundesanstalt für Materialforschung- und Prüfung, Berlin, 2011

### IMPACT ENERGY

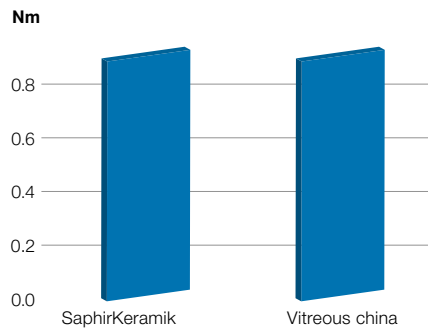

Source: Keramik-Institut GmbH, Meissen, 2011

Simultaneously hard and malleable, SaphirKeramik enables pieces to be made with very thin, yet very strong walls of only 2/16"–3/16" (3–5 mm), as well as with narrowly defined radii of only 1/16" (1–2 mm). The slim profile of SaphirKeramik means that it saves space, is light and environmentally friendly. The new design characteristics of this innovative material are rooted in its exceptional hardness and strength. When the mechanical properties of the two traditional sanitary ceramic masses – namely vitreous china and fine fire clay – are compared, the performance of SaphirKeramik is unique even in international comparison. The comparative values measured by the Federal Institute for Materials Research and Testing in Berlin (BAM) for SaphirKeramik are, at an average of over 120 MPa, comparable with carbon steel and twice as high as for vitreous china.





1



3



2



4

- 1 Production site for the manufacture of SaphirKeramik in Gmunden (Upper Austria)
- 2 Kartell by Laufen washbasin, SaphirKeramik, 2015
- 3 The thin-walled SaphirKeramik was tested for impact resistance at the Keramik Institut Meissen
- 4 SaphirKeramik has a two to three times higher bending resistance than traditional ceramics

# OUTSTANDING DESIGN

Meet internationally acclaimed designs of LAUFEN.



DESIGN PLUS AZ 2016 AWARDS OF MERIT



GOOD DESIGN product design award Interior Innovation award 2013 Winner 2013



GOOD DESIGN



PIA '13 The 2013 International Product Innovation Awards

DESIGN PLUS GOOD DESIGN



product design award 2013



GOOD DESIGN



ELLE DECOR DESIGN AWARDS 2014



GOOD DESIGN GOLD AWARD 2016



reddot award 2014 winner

THE DESIGNERS



- 1 Konstantin Grcic, Konstantin Grcic Industrial Design
- 2 Andreas Dimitriadis, platinumdesign
- 3 Ludovica+Roberto Palomba, Palomba Serafini Associati
- 4 Toan Nguyen, Toan Nguyen Studio
- 5 Peter Wirz, Vetica
- 6 Stefano Giovannoni, Giovannoni Design
- 7 Andreas Haug/Harald Lutz/Bernd Eigenstetter/  
Tom Schönherr, Phoenix Design
- 8 Hee Welling, Hee Welling Studio
- 9 Antti Ylisassi, Design BOD
- 10 Wiel Arets, Wiel Arets Architects



**AWARDED DESIGN**

The aesthetic design and the high creative product quality of LAUFEN products have already convinced a large number of international judges and independent organisations and resulted in awards for individual products, whole series, innovative materials and show rooms.

# THE PRODUCTION

## Global network with local service



### PRODUCTION EXCLUSIVELY IN CENTRAL EUROPE

- 1 The company is named after the town of Laufen near Basel in Switzerland where it has produced washbasins, bidets and toilets in sanitary ceramic for 120 years. The management of LAUFEN Bathrooms AG, faucet production, training centre and the LAUFEN Forum are also located here.
- 2 The production facility in Gmunden specialises in the manufacture of highly sophisticated bathroom sanitary wares. The Gmunden facility has acquired this expertise through a long tradition in ceramics production.
- 3 English earthenware was already produced in 1795 in Wilhelmsburg, Austria. Today, this factory practises the fine art of sanitary ware production.
- 4 The state-of-the art factory in Znojmo, in the Czech Republic, produces high quality bathroom ceramics. This factory has a long tradition which goes back more than 130 years.
- 5 Bechyně is not only the home of the oldest vocational school of ceramics in the Czech Republic, it is also a modern factory where high quality ceramics have been produced for more than 50 years.
- 6 LAUFEN ceramics products are produced in accordance with strict LAUFEN quality standards (LQS) at the state-of-the-art Roca Group factory in Gliwice.
- 7 In addition, LAUFEN bathtubs are made of acrylic and mineral cast materials in Gryfice, Poland.



# SUSTAINABLE QUALITY

## Environmentally-compatible production of durable and resource-saving products



### WATERSENSE CERTIFICATION

LAUFEN's floor mount and wall hanging water closets have been certified to meet the rigid requirements of the WaterSense program. These products meet the WaterSense requirements for both minimal water usage and waste removal exceeding 350 grams. Frequently referred to as High-Efficiency Toilets (HET), LAUFEN's dual-flush technology is used throughout the product line to achieve its HET certification.



### EUROPEAN WATER LABEL

The database of the European Water Label provides architects, planners and consumers with a comparative tool that is valid in the whole of Europe and that allows them to evaluate the water consumption of a water-using product in the bathroom or kitchen at a glance. Find further information in the chapter Product features and benefits.

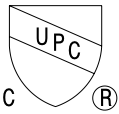

### IAPMO UNIFORM PLUMBING CODE

All of LAUFEN's ceramic products (unless noted otherwise in the price list) meet the design requirements and laboratory testing demands of the Uniform Plumbing Code (cUPC) and American Society of Mechanical Engineers (ASME). Organizations that provide this testing routine include the International Association of Plumbing and Mechanical Officials (IAPMO Group), that have issued several of LAUFEN's certifications.



### ENVIRONMENTAL PROTECTION STANDARDS

Since 1998, LAUFEN has continually monitored the use of resources in all its internal and external processes. Targeted measures and appropriate investments promote the efficient and sustainable use of manufacturing resources. Important key environmental protection indicators now clearly show that LAUFEN production sites fulfil the legally-prescribed environmental protection standards, and in most cases also exceed them.



### ECONOMIC WATER FLUSH SYSTEMS

LAUFEN's 4.5/3-litre toilets meet all functional requirements defined by international standards EN 997 Class 1 Type 5, EN 997 Class 2 and SAI/Wels 4 Stars. Please take into consideration your local requirements that can vary from country to country. Find further information in the chapter Product features and benefits.



### CERTIFICATION

The first two LAUFEN production facilities were successfully ISO 14001 certified and EMAS registered in 1997. Both of these factories were awarded the European Environment Prize 2007 for exemplary environmental management.

All the LAUFEN production facilities are now certified with the Environmental and Quality Management Systems ISO 9001 and ISO 14001.



### SWISS QUALITY

Products with the Q-Plus certification meet both the European standard and the established more stringent Swiss suis-setec/VSA standard. LAUFEN sanitary ware products meet these Swiss quality standards and have been recommended for approval accordingly.

# THE REFERENCES

Buildings all over the world by renowned architects using LAUFEN.



Hungerburg Funicular, Innsbruck, Zaha Hadid



Otkrytie Arena, Moskau, AECOM und Dexter Moren Associates



Demonstrating its commitment to the project sector, LAUFEN has strengthened its global team, ensuring that its extensive product range is backed up by the very best levels of customer service and support. LAUFEN can support clients all over the world with a dedicated global projects team based in the design centres of London, New York, Singapore and Dubai.



Library of the Jurisprudential Institute, Zurich, Santiago Calatrava



International Commerce Centre, Hong Kong, Kohn Pedersen Fox Associates



Olympiastadion, Berlin, by Gerkan, Marg and Partner



FH Campus Vienna, Delugan Meissl



Changi International Airport, Singapore, Woodhead

HOTELS



Barin Ski Resort, Tehran, Ryra Studio



Hilton Bora Bora Nui Resort & Spa, Bora Bora



Sheraton Melbourne Hotel



Intercontinental Hotel, Warsaw, Jestico + Whiles



Hotel Silken Puerta America 1st floor, Madrid, Zaha Hadid



W Hotel, Barcelona, Ricardo Bofill



RESIDENTIAL



Brammy Residence, Adelaide,  
Tropo Architects



Gasometer, Vienna, Coop Himmelb(l)au, Photo: Gerald Zugmann



Tom Dixon Watertower House, London, SUSO



BC House, Monterrey, Gilberto L. Rodriguez, Photo: Jorge Taboada



The Lily, Hong Kong, Foster + Partners



Market Hall Rotterdam, MVRDV,  
Photo: Daria Scagliola and Stijn Brakkee

# IL BAGNO **ALESSI** One







The architect and designer, Stefano Giovannoni, born 1954 in La Spezia (Italy), lives and works in Milan. His work has received international acclaim. A number of his designs can be found in the permanent collections of the Centre Georges Pompidou in Paris and the Museum of Modern Art in New York. According to Alberto Alessi, the Managing Director of ALESSI, Giovannoni is one of the few designers who understands how to combine the unusual with the popular, which is also why he was commissioned to develop the first complete bathroom scenario for ALESSI.



**DESIGN PLUS**



The iconic washbasin from the collection is also available as a countertop washbasin in 90 cm and 120 cm, right-hand and left-hand versions, particularly suitable for smaller rooms.



A free-standing bathtub made from solid surface in a gentle, comfortable shape with or without whirl system. Also as a fitted version.





The collection is complemented by new accessories of functional and symbolic value, including a shelf with integrated towel holder, made from revolutionary SaphirKeramik. Toilet roll holders and clothes hanger are also available.

The playful, slightly eccentric form of the washbasins is quite iconic and fires the imagination without compromising functionality. The wide variety of ILBAGNOALESSI One washbasins demonstrates that good design can take more than one shape. From the small washbasin to the countertop washbasins, the character of the range is unmistakable. Most washbasins have a concealed ceramic overflow system. The ceramic of the washbasins is finished with LAUFEN Clean Coat, making it particularly easy to clean.









The sanitary ware with its poetic design language was created by the prolific Italian designer, Stefano Giovannoni. ILBAGNOALESSI One includes not only the characteristic and spectacular washbasins, but also an aesthetically-pleasing high-quality and functional range of furniture, bathtubs made of solid surface and sanitary acrylic as well as accessories made from SaphirKeramik.













An icon of contemporary design: the floor-mounted TamTam by LAUFEN opens up new dimensions in bathroom design. The taps, mounted on the rim of the basin, wall-mounted or floor-standing, combine perfectly with the washbasin. Behind this lies an exceptionally high degree of functionality: invisible overflow, concealed connection hoses, hidden mounting.



The surfaces are top-quality Noce Canaletto real wood veneer or white high-gloss lacquer with a quartz cover plate. It goes without saying of course that all surface finishes are not sensitive to water.

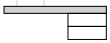

# POSSIBLE WASHBASIN/COUNTERTOP COMBINATIONS

Countertop	31 8/16" (800 mm)	47 4/16" (1200 mm)		63" (1600 mm)	
Optional drawer elements	 42301.3	 42311.1	 42311.2	 42321.4	 42321.1
Washbasin					42321.1
<b>ILBAGNOALESSI ONE</b>					
 81197.3 Ø 17 11/16" (Ø 450 mm)	●	●	●	●	●
 81397.1 Ø 19 11/16" (Ø 500 mm)	●	● /R Drawer element 42440.2	● /L Drawer element 42440.2	●	● /R Drawer element 42440.2, 42442.2
 81897.3 31 8/16" x 16 9/16" (800x420 mm)	●	● /R Drawer element 42440.2	● /L Drawer element 42440.2		● /R Drawer element 42440.2, 42442.2

● can be combined with a washtop

M can be combined with a central drawer element

78 12/16" (2000 mm)

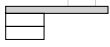

42321.2

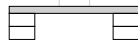

42325.3



42325.4



42325.1

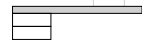

42325.2



● /L  
Drawer element  
42440.2, 42442.2

● /L  
Drawer element  
42440.2, 42442.2



● /L R  
Drawer element  
42440.2

● /L R  
Drawer element  
42440.2



● /M  
Drawer element  
42440.2



● /R  
Drawer element  
42440.2, 42442.2

● /R  
Drawer element  
42440.2, 42442.2



● /L  
Drawer element  
42440.2, 42442.2

● /L  
Drawer element  
42440.2, 42442.2

L can be combined with a left-hand drawer element

R can be combined with a right-hand drawer element

# IL BAGNO **ALESSI** dOt



ILBAGNOALESSI dOt – a cooperation between Alessi, LAUFEN Bathrooms and Oras – is the first bathroom project of the designer, Wiel Arets.

In drawing up the design, Arets paid particular attention to ensuring that the individual objects did not distract from the real purpose of the bathroom – to cleanse the body and spirit.

Wiel Arets: “The ensemble as a whole is based on the strengths of its individual parts. Each must fulfil its purpose without becoming overly dominant. All objects must, in all respects, serve the purpose of relaxation. The design of the forms is very low key yet consistent for all objects which means they project an overall impression of peace and tranquillity.

On closer inspection, it can also be seen that their form perfectly follows their function.” While the designs of the Dutch architect and designer Wiel Arets are undoubtedly based on intellectual concepts, they are also pragmatic.

His most significant work includes the Academy of Art and Architecture in Maastricht and the AZL Pensions Fund Headquarters in Heerlen, Netherlands.

Wiel Arets was born in 1955 in Heerlen and received his diploma from the Technical University of Eindhoven in 1983. In 1984, he founded the office Wiel Arets Architect & Associates in Heerlen, which subsequently moved to Maastricht in 1996. He has lectured all over the world at academies and universities in London, Vienna and New York and other cities. He currently holds the Berlage professorship at the Technical University of Delft.



Design: Wiel Arets



Formal and minimalistic: this is the impression created by the elements of ILBAGNOALESSI dOt. The unifying key element is the circle – even if this is not always obvious. The highly minimalist design with closed form and low-key elegance radiates an air of tranquility.



# PALOMBA COLLECTION









With the introduction of the successful LAUFEN PALOMBA COLLECTION in 2005 the famous Italian designers Ludovica and Roberto Palomba created a design language that the couple describe as a “fingerprint of nature”. The tension between rigorous geometrical and organic shapes is typical of the entire collection, and ensures that all elements can be combined with one another. If recent editions have favoured geometrical shapes, this time round the Milanese designers are again focusing more on soft organic lines. The highlights of the PALOMBA COLLECTION are the “Menhir” washbasin and an exceptional bathtub. These two leading protagonists are accompanied by a cast of four countertop washbasins, two washbasin bowls and a new bathroom furniture collection.





reddot design award  
winner 2005



reddot design award  
winner 2007



product  
design award  
2007



product  
design award  
2013



MANUFACTURER  
AWARDS 2005



interior  
innovation  
award  
2013  
Winner



GOOD  
DESIGN



GOOD  
DESIGN



INTERIOR  
DESIGN  
BEST  
OF  
YEAR HONOREE  
2012

## DESIGN PLUS



LAUFEN extends its range of washbasins introduced in previous editions of the collection by four countertop washbasins in 50, 65, 80 and 100 cm lengths. An organically shaped bowl blends lagoon-like into the ultra-flat washbasin panel. The central position of the bowl leaves ample storage space at either side.

To match the ceramic washbasin LAUFEN has created a bathroom furniture series for the PALOMBA COLLECTION. It includes vanity units whose handles and bases can be optionally selected with atmospheric LED lighting, a tall cabinet, medium cabinet and washtops





The PALOMBA COLLECTION offers endless creative possibilities, as many of the objects can be combined with each other. LAUFEN has set itself the task of continuously adding new design solutions to the PALOMBA COLLECTION. The versatile design tonalities give architects, interior decorators and designers a wide selection of superior quality, up-to-date products at their disposal in the planning of bathrooms, thus offering them a great opportunity: To break free from all clichés and have full design freedom.







Innovative axialities: organic decisive lines for a large washbasin that characterize and shape the entire range of architectural objects. A unique product in the world of sanitary wares which poses a real challenge to the laws of production. This iconic 63" (1600 mm) washbasin is also available in widths of 47 4/16" (1200 mm) and 31 8/16" (800 mm). Together with the asymmetric washbasin bowl, this washbasin won the coveted red dot design award.



The bathroom is also architecture. This room can become a real part of the home by devising bathtub, washbasin, WC, bidet and furniture configurations. The WC and bidet in white ceramic are available as a floorstanding bidet/WC, wall-hung bidet/WC and WC with cistern. The toilet seat has a lowering system. The WC seat with ultra-flat cover fits existing stylish WC versions.





Symmetrical and asymmetrical bathtubs made of acrylic and Sentec mineral material. The PALOMBA COLLECTION takes pure geometry to a new level. A modern international bathroom, thanks to essential shapes that are unique, sensual and readily combinable. These innovative and unprecedented creations mark the start of a new chapter in the art of bathroom design.



◆ SaphirKeramik



Since its launch Kartell by LAUFEN has celebrated great successes with clients, at design events, award ceremonies and trade shows around the globe. Now, with an exciting range of new products, LAUFEN is opening another chapter in this success story. New to the range is a 120 cm wide washbasin made from SaphirKeramik. This generously sized piece is perfect for larger washing areas. Also new is a 90 cm washbasin with a shelf on the right, an extremely compact guest basin with storage on the right or left. This range is made from SaphirKeramik and includes innovative features such as a special hidden outlet and optional invisible overflow.



ELLE  
DECO  
INTERNATIONAL  
DESIGN AWARDS









To this collection we have also added an easy to clean rimless toilet and space saving vanity units for guest bathroom washbasins. Also new are the vanity units with one or two drawers for 90cm and 120cm washbasins. With its new products Kartell by LAUFEN furthers its reputation as a complete bathroom collection, offering innovative and stylish options for exceptional bathrooms, both compact and generously sized.









The new line of fittings in the Kartell by LAUFEN range combines quality design and pure lifestyle in one. LAUFEN has now expanded its range with elegant fittings and single lever operation. To select from is a washbasin faucet, a column faucet for countertop bowls as well as a bidet faucet with swivel spout and individually positionable operation.

LAUFEN complements the Kartell by LAUFEN fittings range with a wall-mounted faucet for washbasins, bathtubs and showers. They provide the user with a convenient storage space for personal accessories and can be installed quickly and easily.



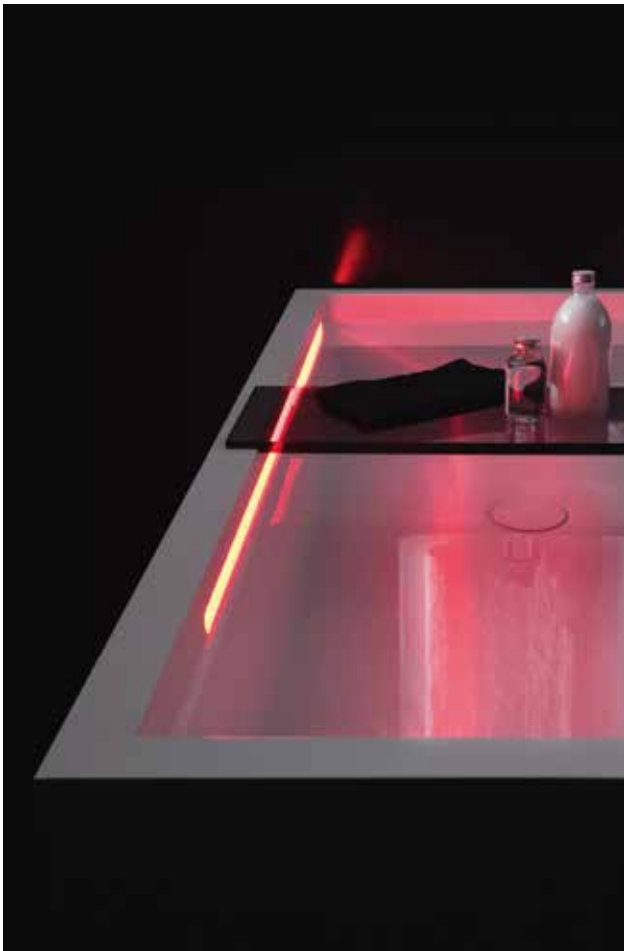





# LIVING CITY



A system with corners and edges, yet so flexible and easy to maintain: living city has a clear concept and clear forms. Thanks to the modular system, washbasins with and without storage are available in many widths. Reduction, not stone cold sobriety; individualism without idiosyncrasy: The language of the living city forms is aimed at people who live in modern surroundings and create a living environment with refined awareness and sensitivity to materials. The design of LAUFEN rectangular wall-hung WCs and bidets suits this context perfectly.









Urbane and modern: living city demonstrates a bold tendency towards reduction and interprets sanitary ware as a cube. This bathroom design is characterised by a clear line and aesthetic sophistication.

Pure geometry: The sanitary ware products of living city speak a clear formal language are a celebration of modern lines.

Case, the bathroom furniture series, is the perfect compliment and provides more storage space for all living city washbasins (see chapter "case").







## WC & Bidet

The rectangular wall-hung WC and wall-hung bidet of the living series harmonise perfectly with the washbasins of the living city and living square series. Hygienic LCC special glaze, WC seats with lowering system and always with economy-flush capability.

# LIVING SQUARE





living square pushes the art of ceramic manufacturing to its limits. The extremely flat washbasin, with its flat surfaces and defined edges, appears to float in front of the wall. This is how elegant sanitary ware can be. living square inspires with its slender outline: The double washbasin, with a useful width of 180 cm in combination with the ceramic shelf, creates a fully functional washing facility. The case range of furniture is equally well matched (for more information see the chapter "case").





Different configurations are possible for the living square washbasin: traditional wall mounting; incorporated in a furniture unit; as a back-to-wall washbasin bowl; recessed into the top of a countertop or with additional practical towel holder.





The living square washbasins are cutable and can be trimmed to almost any requirement: on the right, left or at both ends. Thanks to precision engineering, they can be cut in our factory to within a millimetre of customer specifications. This means we can produce tailor-made solutions that fit perfectly into niches and corners.





living square inspires with its slender outline: The double washbasin, with a useful width of 180 cm in combination with the ceramic splash back, creates a fully functional washing facility.

# LIVING SAPHIRKERAMIK

◆ SaphirKeramik





Design: platinumdesign,  
Andreas Dimitriadis

LAUFEN really makes the most of the advantages of the SaphirKeramik material: New possibilities and flexibility regarding the modelling of ceramic can now be seen clearly in the delicate, thin-walled shapes and narrow radii of the SaphirKeramik. To complement the revolutionary Living SaphirKeramik bowls, LAUFEN offers simple yet elegant furniture which shows off the delicate bowls in the right light. The floor-standing furniture units are connected to the wall and available in two sizes to suit all of the washbasin bowls.



**PIA'13** : The 2013 Architectural Products  
Product Innovation Awards

**DESIGN PLUS**



LB<sup>3</sup>



Perfect combination with contemporary furnishings: Lb3 classic is the formal language of the middle-class living environments of the 19th century – adapted to the present day and uncapricious. The double contour lends the washbasin a timelessly elegant and light appearance. As washbasin with pedestal or siphon cover, as cutable countertop washbasin or as built-in washbasin – Lb3 classic offers a wide selection that gives you ultimate flexibility when choosing your fixtures and fittings. This range offers a nod to the past – yet is still highly contemporary in terms of its design: furniture in white, oak or wenge. For wall-mounting or flexible installation on chrome-plated metal feet. Tall cabinets with glass shelves can store a great deal ensure the bathroom stays tidy. Perfection down to the last detail: The accessories are perfectly matched to the design of the three Lb3 versions and have sophisticated chrome fittings.





Whether floorstanding or wall-hung, whether with face mounted or recessed cistern: the Lb3 WC and bidet range is convincing due to its variety – with or without lowering system. In the classic variant, the double contour is applied to the WC lid, and is kept simple in the modern and design versions. The WC and bidet sanitary ware range is the same for all Lb3 versions. Many convincing practical details: bidet overflow without overflow hole and concealed fixings for WC and bidet.



# INO

◆ SaphirKeramik







A fine feeling for the trends and developments in business and the environment characterise the design of Toan Nguyen: With his design studio, the Toan Nguyen Studio, he designs products that lend the spirit of the times a timeless shape. Toan Nguyen was born in Paris in 1969 and graduated in 1995 as an industrial designer from ENSI-Les Ateliers in Paris. Nguyen gained experience by working at various design offices in Paris, Barcelona and Madrid, before starting a 10-year collaboration as a design director and design partner with Antonio Citterio in 1998. During this period, he came up with designs for brands like Axor Hansgrohe, B&B Italia, Flos, Fusital, Guzzini, Iittala, Kartell, Metalco, Skantherm, Technogym and Vitra. Toan Nguyen established his own design studio in Milan in 2008.

#### **WEIGHTLESS AESTHETIC**

The new bathroom collection Ino, designed for LAUFEN by French designer Toan Nguyen, understands itself as a fresh interpretation of classic washbasin forms. The innovative collection skilfully uses the creative possibilities of LAUFEN's SaphirKeramik. Elegant, inviting and almost weightless objects, the pieces work with simple lines, creating soft yet extremely stable walls. The collection includes a wall-mounted washbasin, a countertop or half inserted washbasin bowl, as well as high-quality bathroom furniture and two bathtubs.





One of the collection's stand out features is its sensational washbasin with seamlessly integrated console. The easy-to-clean shelf, which defines the space next to the generous washbasin has a drawn up back wall, and can be located on the left or right of the washbasin. In 2015 this piece was awarded the coveted Design Plus Award by the ISH jury.

A free-standing bathtub made from Sentec is available in 66 15/16" x 29 8/16" (1700x750 mm) and 70 14/16" x 31 8/16" (1800x800 mm) forms, including an integrated headrest and creates a relaxing atmosphere. With its narrow edges the oval tub looks as delicate as the washbasins made from SaphirKeramik. The piece, distinguished by its light weight, is made with a single layer cast from a single mould.





Ino also includes wall-mounted washbasins in 17 11/16" and 22 1/16" (450 and 560 mm) widths and washbasin bowls in widths of 13 12/16" and 19 11/16" (350 and 500 mm), which are available as countertop or as half-inserted versions.



Nguyen has also designed a set of bathroom furniture that visually and functionally accompanies his Ino collection. A highlight is the ultra-thin panel on the drawer made from real wood veneer or mirrored aluminium, which seamlessly flows over the sides and base of the cabinet making it appear as one piece. A matching cupboard with a corner door is also available.



VAL

◆ SaphirKeramik





Munich designer Konstantin Grcic is not only one of the most influential designers of his time, he is also renowned for his ability to stretch new materials and production methods to their limits. With the new SaphirKeramik range, we offered Grcic the opportunity to redefine and push the creative boundaries of bathroom ceramics. The intensive collaboration started with the SaphirKeramik project and focussed on a series of spectacular concept studies based on washbasins with a decorative, functional surface.

### FUNCTION AS ORNAMENT

The extraordinary design potential of LAUFEN's revolutionary SaphirKeramik reveals itself in the new bathroom collection Val, designed for the Swiss bathroom specialist by star designer Konstantin Grcic from Munich. Simple architectural lines, extremely narrow edges and fine surface structures make the washbasins of this collection globally unique. The Val range includes washbasins, washbasin bowls, trays, bathtubs and new bathroom furniture from the Space collection.





The rectangular, wall-mounted washbasin, is available in 6 widths from 17 11/16" x 37 6/16" (450 to 950 mm). Its trademark, straight geometric lines and walls with small radii and gently rounded corners emphasise the humane and friendly character of the delicate SaphirKeramik.











Suited to the SaphirKeramik objects, Konstantin Grcic has designed a compact, free-standing bathtub in the dimensions 63" x 29 8/16" x 20 8/16" (1600x750x520 mm). The oval tub weaves a sense of harmony into the bathroom with its lightness and elegance, created by its extremely narrow edges, and fits perfectly with fine washbasins. As LAUFEN manufactures the bathtub from the solid surface material Sentec, it can be crafted as a single layer in one mould without sacrificing integrated overflow, while also reducing the bathtub's weight.

Val also includes a rectangular and an asymmetrical washbasin bowl as well as a partially concealed washbasin, each of which is equipped with built-in storage space and has a tactile surface texture that creates semi-dry areas. Also belonging to Val are circular and rectangular storage trays made of SaphirKeramik, both of which have tactile surface structures. All washbasins are available with or without overflow.





# PALACE











A timeless classic, conceived with the future in mind: palace has developed into a complete multi-faceted bathroom solution. But its speciality remains: To provide cuttable washbasins tailored to the measurements of any bathroom.

Palace's designer, Andreas Dimitriadis of platinumdesign, has put together a bathroom range that is as suitable for the private home as it is for the hotel bathrooms of the world. It is a homage to the ceramic material, taking advantage of its strengths in both applications.



Bathroom Furniture chapter



reddot design award  
winner 2011



German  
Design Award  
NOMINEE 2013

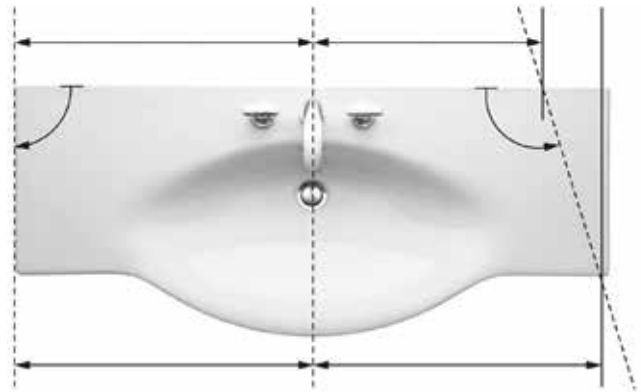

The large palace washbasins (from a length of 120 cm) can be ordered made-to-measure from our factory. Thanks to our innovative production engineering, our sanitary ware fits precisely into bathroom plans. The sanitary ware can be cut, also diagonally. Freestanding side components can also be manufactured to precise measurements without having to add on side panels with visible joints.



Whether wall-mounted or floor-standing – the range of palace WC and bidet models covers all applications. Ingenious: An ergonomic form, with concealed mountings. An optional WC seat with lowering system is also available.



# LAUFEN PRO





LAUFEN has extended its successful LAUFEN pro bathroom range, and updated its design. It has enhanced this already comprehensive bathroom range, which offers the ideal solution for every spatial situation and requirement and also reflects the building values of the current generation. Industrial design is the modern answer to the once revolutionary idea that everyone has a right to enjoy beautiful forms. Good design is now no longer a right reserved for the most affluent customers. Modern methods of industrial production and designers such as Peter Wirz of Vetica, who put optimum manufacturing feasibility at the forefront of their creative processes, make such sanitary ware ranges as LAUFEN pro possible. This does not just benefit the designer, more importantly, it also benefits the customer.



reddot award 2014  
winner



universal design  
consumer favorite 2011



universal design  
award 2011

# LAUFEN PRO S



The Swiss designer Peter Wirz is also responsible for LAUFEN pro S. With heaps of sensitivity, he brought about a systematic, production-optimised evolution of the pro concept: Thanks to its slim silhouette and clearly-defined radii, the washbasin has a light and elegant appearance. The deep bowl means that it's also functionally appealing. The aesthetics of LAUFEN pro S therefore definitely take the range in the direction of LAUFEN's premium design lines – while remaining affordable by all.









Slimmer, lighter and bolder - LAUFEN pro S is the new family member that supplements the successful LAUFEN pro series. Thanks to the careful redesign, the elegant pro S is compatible with all pro variants.

If space is scarce, good ideas are required. LAUFEN pro compact solutions give you the opportunity to devise a comprehensive design concept, even in the most restricted spaces. Our washbasins and WCs have a short projection which saves valuable space.





The new LAUFEN pro S WC is a geometric wall-hung WC which comes with a matching bidet. It fits in perfectly with the redesign of the LAUFEN pro S washbasins. Thanks to the concealed LAUFEN EasyFit mounting system (PCT pat. pend.), the ceramics have a flawless appearance and are easy to clean.







The elegant and subtle LAUFEN pro S furniture-mounted washbasins with deep, highly functional bowls and generously sized shelves are new to the range. These are only available together with the matching furniture in the range.



# LAUFEN PRO A

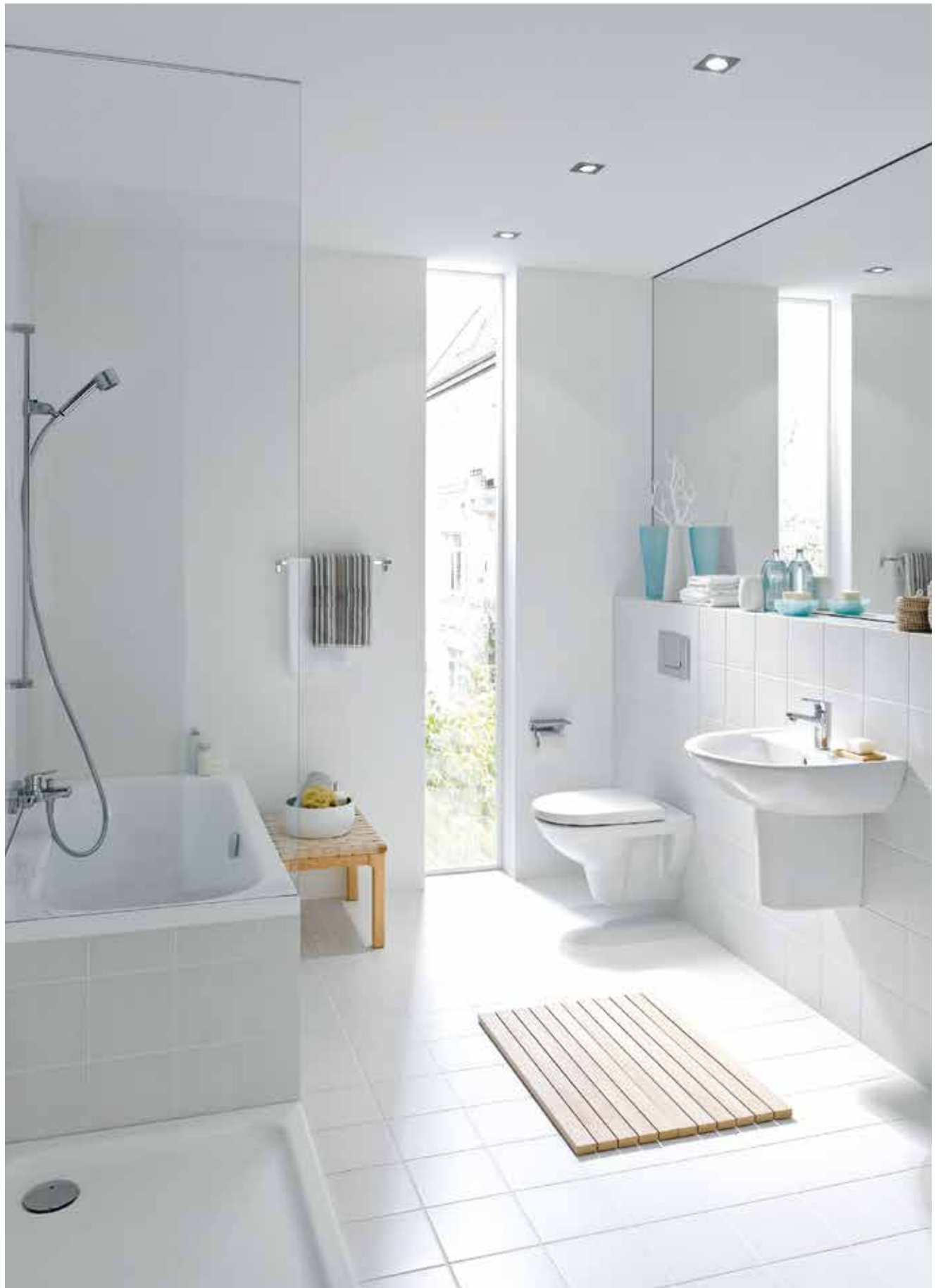

Elegance and function combined. Semicircular washbasins in a large number of sizes. Suitable for any type of use. The elegant shape is striking, as well as the raised rim. This is a washbasin which makes a good impression everywhere. It is thus logical that it is available in a large range of sizes and styles.

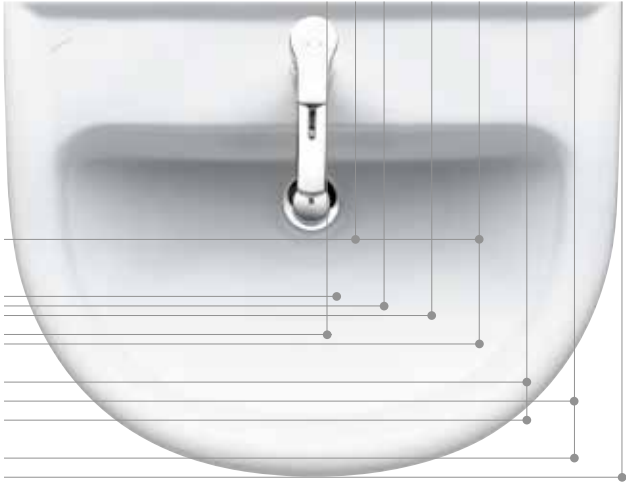





Reduction as design principle. Simple, no-nonsense rectangular washbasins. Pro as in professional – A for Architecture. A simple rectangle is the basic shape, and the special rim that prevents overflow is a design feature that is also functional.







# LAUFEN PRO WCS AND BIDETS





LAUFEN pro includes WCs and bidets for all applications.



➔ LAUFEN EasyFit system  
Product properties chapter

# WASHBASIN BOWLS



The original washbasin. What was once effectively a portable water container now provides elegant highlights in the bathroom. The washbasin bowl embodies a timeless chapter in bathroom history. More and more designers are now combining the light appearance of the washbasin bowl with suitable vanity units, which restores a great deal of authenticity to the bathroom.



ILBAGNOALESSI One  
€1897.3



Options: .112



ILBAGNOALESSI One  
€1197.3



Options: .109



PALOMBA COLLECTION  
€1680.1



Options: .112



PALOMBA COLLECTION  
€1680.2



Options: .112



PALOMBA COLLECTION  
€1680.3



Options: .104



Kartell by LAUFEN  
€1233.1



Options: .112



Kartell by LAUFEN  
€1233.2



Options: .104 .136



living square  
€1143.3



Options: .112



living square  
€1143.4



Options: .112



living square  
81143.5

○



living city  
81143.1  
81143.2

○/●



VAL  
81228.1

○/●

Options: .112

Options: .104 .109  
also for 81143.1/.2  
.136

Options: .104 .109 .111 .112



VAL  
81228.2

○



INO  
81230.0

○



INO  
81230.2

○

Options: .109 .112

Options: .109 .112

Options: .109 .112



LAUFEN pro S  
81295.2

○/●/●●●



LAUFEN pro  
81296.4

○



LAUFEN pro  
81296.2

○

Options: .104 .109 .136

Options: .109

Options: .109

# WASHBASINS, UNDERSURFACE GROUND



The ground flat underside of the wall-mounted washbasins shown here is placed on the furniture. When ceramic bowls are combined with stone, wood or metal bases, this opens up a wide range of interior design possibilities.



LAUFEN pro S  
81696.1

Options: .104 .109

o/●



VAL  
81628.0

Options: .104 .109

o/●



VAL  
81628.2  
81628.3  
81628.4  
81628.5  
81628.7

Options: .104 .109 .136

o/●/●/●/●



INO  
81630.0  
81630.2

Options: .104 .109

o/●



# SEMI-RECESSED WASHBASINS



The recessed washbasins project out from a slender, space-saving countertop. In hotel bathrooms, and wherever space is limited, semi-recessed washbasins are an elegant solution that allow greater freedom of movement.



living  
s1343.2

o/●●●●



living  
s1343.1

o/●

**Options:** .104 .109 .136

**Options:** .104 .109

# DROP-IN WASHBASINS



The ceramic basin is lowered from above into the cut-out in the washtop. In contrast to washbasin bowls, the underside is not ground flat, as the washbasin is not supported at the bottom. Bathrooms can be designed to individual requirements using a combination of washtops and bowls with a wide variety of forms and colours.



ILBAGNOALESSI One  
81397.1

Options: .104 .109

o/●



living square  
81643.1  
81643.2  
81643.3  
81643.4

Options: .104 .109 .136

o/●/●●●



VAL  
81728.1

Options: .105 .106 .109 .112 .113 .114

o/●



INO  
81730.1  
81730.2

Options: .109 .112

o



LAUFEN pro S  
81896.3

Options: .104 .109 .136

o/●/●●●



LAUFEN pro A  
81395.1

Options: .104

●



LAUFEN pro A  
81396.1

Options: .104

●

# BUILT-IN WASHBASINS



Built-in washbasins blend effortlessly into your bathroom. The ceramic bowl is installed in the washtop from below. The flush fit between the bowls and natural stone, plastic or wooden countertop makes the ensemble easy to clean.



living city  
81243.0  
81243.1\*  
81243.2\*  
81243.4

\*ground

Options: .109 .155



○ LAUFEN pro S ○  
81196.1  
196.8  
81196.9

Options: .109 .155



# HIJET WC



HiJet is a new type of WC equipped with the highest-performance flushes containing volumes of 4, 5/3 and 6/3 liters. This unique model unites all current worldwide standards with maximum performance tests showing that this powerful WC is prepared to meet future standards as well. It currently achieves outstanding flushing results with 2–3 liters with its downstream drainage systems that are designed for this purpose. LAUFEN currently has a patent pending for this new flushing system. In addition, LAUFEN has developed a revolutionary wall fixation system for WCs, bidets, and urinals. EasyFit, the invisible, easy to mount fixation system meets the needs of both fitters and end users. A patent is also pending for this innovative product.

- High performance flush
- Eco friendly
- Easy to clean
- Contemporary design
- Flushing system – PCT patent pending
- EasyFit fixation – PCT patent pending

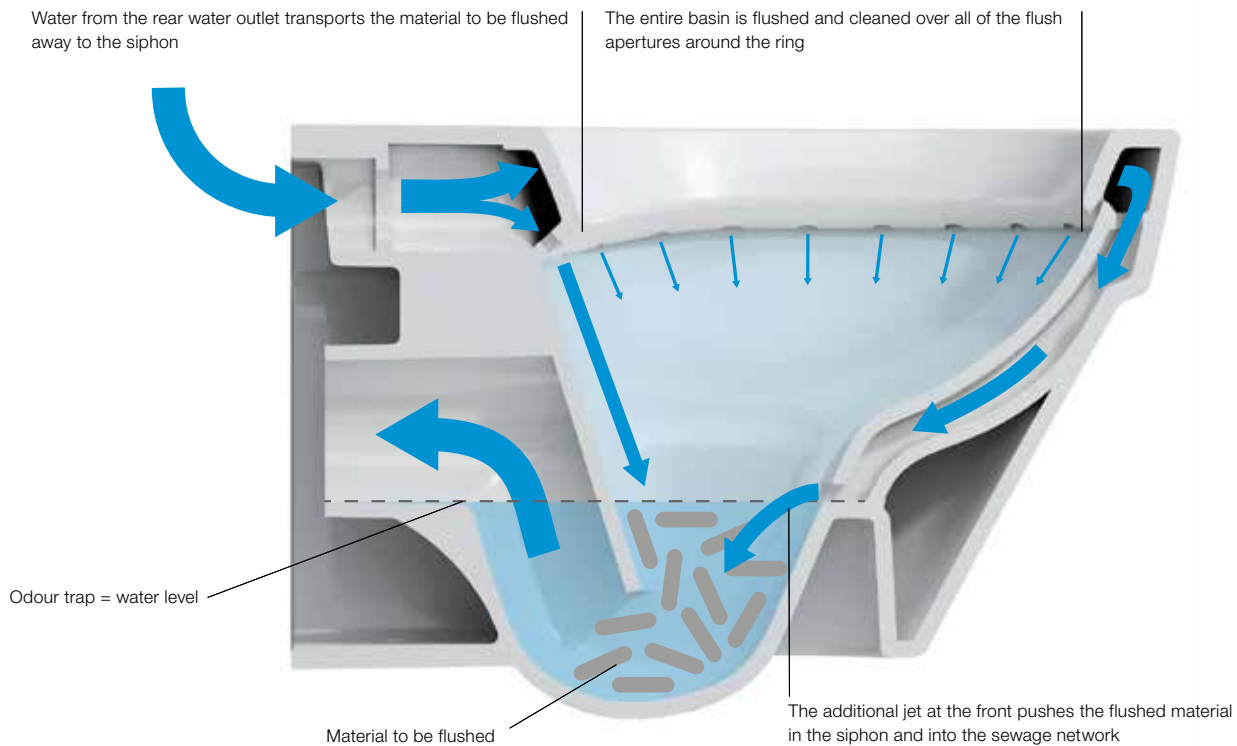

# ONE PIECE TOILETS







# BATHROOM FURNITURE





It's hard to believe that we spend a large proportion of our lives in the bathroom. And for precisely this reason the bathroom, a place where we retreat to relax and take some time out of the daily grind to recharge our batteries, needs to have a special atmosphere. The harmonious bathroom furniture meets the highest aesthetic and functional standards – which means you savour those valuable moments in the bathroom all the more intensely.









































# WHAT GOES WITH WHAT?

## Ceramics - furniture combination options

















	LAUFEN ceramic series										
	Countertop washbasins, bowls										
LAUFEN furniture programs Vanity units, washtops for countertop washbasins and bowls	Il Bagno Alessi One	Palomba Collection	Kartell by Laufen	Living City	Living Square	Lb3	Ino	Val	Palace	Laufen Pro S	Laufen Pro
Boutique		●	●		●		●	●			
Case		●		●	●				●	●	●
Space								●			
Il Bagno Alessi One	●										
Palomba Collection		●									
Kartell by Laufen			●								
Lb3						●					
Ino							●				
Laufen Pro S										●	
Laufen Pro											●

# OVERVIEW OF FURNITURE COLOURS

## Standard colours

					
Boutique	Light oak	Dark oak			
					
Case	White matt	White glossy	Chalked oak	Anthracite oak	
					
Space for VAL	White matt	Light walnut	Dark elm		
					
Il Bagno Alessi One	White glossy	Noce Canaletto			
					
Palomba Collection	White	Cherry Vermont dark			
					
Kartell by Laufen	White glossy	Grey matt	Black glossy	Orange glossy	
					
Lb3	White	Wenge	Oak		
					
INO	White matt	Dark walnut			
					
Laufen Pro S	White	White glossy	Graphite	Wenge	Bright Oak
					
Laufen Pro	White	White glossy	Wenge		

							
colours boxes			back walls				
							
metallic			plastics				

For available colours please refer to the pricelist

# CASE





Compact, functional design is the main success factor in both collections. Case can be combined with many LAUFEN sanitary ware ranges. The rigorous straightforward forms bring out the best in any sanitary ware.

Timeless yet contemporary – case fits in almost any environment. The white scratch-resistant surfaces or contemporary wood structure surfaces of this continuously updated classic make it a compelling choice.





The case furniture range features a high-quality storage concept, suitable for combination with the living square range, among others – and which also represents extremely good value for money. Its ability to make the bathroom neat and tidy at all times is good for both mind and body. One of many technical refinements is the space-saving siphon which dispenses with the need to make siphon cut-outs which means all the space in the vanity unit can be used without restriction.





The case vanity unit, used here in combination with palace, can hold a great deal behind its soft closing doors and in its fully extendable drawers. Optional: one or two drawers.



Special details in a cubist form: The washbasins in the living city range are particularly suitable for flush integration of the furniture.

# SPACE



## **LIGHT AND SPACIOUS AT THE SAME TIME**

With Space, LAUFEN presents a bathroom furniture collection that is based on the lightness of SaphirKeramik, translating it into clear, architecturally minimal forms. Typical for LAUFEN, Space knows how to convince with practical details and high-quality equipment. Space includes vanity units in widths 17 11/16"–37 6/16" (450–950 mm), which can be combined with washbasins from LAUFEN's Val range.





In addition, 8/16" (12 mm) thick washtops of up to 78 12/16" (2000 mm) in length and drawer units in widths from 17 11/16 to 31 8/16" (450 to 800 mm) are available. Several LAUFEN washbasins can be combined with these washtop solutions. The range complements a variety of high cabinets, including those with double-sided mirrors, gently closing doors, available as open versions or as narrow rack.



# BOUTIQUE



### THE LIGHTNESS OF THE ROOM

For weightless elegance in the bathroom LAUFEN offers its new furniture collection Boutique. Clear cubes and a sophisticated design language with tapered edges offer a perfectly shaped storage space to the bathroom, blending harmoniously with the subtle forms of SaphirKeramik washbasins. At the same time, user friendliness is not compromised. Intelligent and unobtrusive solutions such as push-and-pull drawers that gently and quietly open and close with just light finger pressure, allow a simple, even playful experience.







Boutique also includes vanity units, which can be combined with a range of washbasins from LAUFEN's premium collections, including open, combinable furniture modules and a spacious tall and medium cabinet.







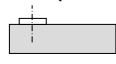



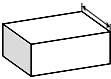

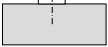



















# POSSIBLE COMBINATIONS BOUTIQUE

 <b>11 13/16"</b> <b>(300 mm)</b>	<b>35 7/16" (900 mm)</b>  <b>40900.3</b>	<b>47 4/16" (1200 mm)</b>  <b>40903.3</b>	<b>47 4/16" (1200 mm)</b>  <b>40903.1</b>	<b>47 4/16" (1200 mm)</b>  <b>40903.2</b>	<b>47 4/16" (1200 mm)</b>  <b>40903.4</b>
<b>KARTELL BY LAUFEN</b>  <b>1533.1</b> 18 2/16" x 18 2/16" (460x460 mm)	●	●	●	●	●
 <b>1033.4</b> 23 10/16" x 18 2/16" (600x460 mm)	●	●	●	●	
 <b>1033.5</b> 23 10/16" x 18 2/16" (600x460 mm)	●	●	●	●	
 <b>1033.8</b> 35 7/16" x 18 2/16" (900x460 mm)	●	●	●	●	
 <b>1033.9</b> 35 7/16" x 18 2/16" (900x460 mm)	●	●	●	●	
 <b>1333.2</b> 47 4/1" x 18 2/16" (1200x460 mm)		●			
<b>VAL</b>  <b>1628.0</b> 17 11/16" x 16 9/16" (450x420 mm)	●	●	●	●	●
 <b>1628.2</b> 21 10/16" x 16 9/16" (550x420 mm)	●	●	●	●	●
 <b>1628.3</b> 23 10/16" x 16 9/16" (600x420 mm)	●	●	●	●	
 <b>1628.4</b> 25 9/16" x 16 9/16" (650x420 mm)	●	●	●	●	
 <b>1628.5</b> 29 8/16" x 16 9/16" (750x420 mm)	●	●	●	●	
 <b>1628.7</b> 37 6/16" x 16 9/16" (950x420 mm)		●	●	●	
<b>INO</b>  <b>1630.0</b> 17 11/16" x 16 2/16" 450x410 mm	●	●	●	●	●
 <b>1630.2</b> 22 1/16" x 17 11/16" (560x450 mm)	●	●	●	●	●

	19 11/16" (500 mm)	35 7/16" (900 mm)	47 4/16" (1200 mm)	47 4/16" (1200 mm)	47 4/16" (1200 mm)	47 4/16" (1200 mm)
						
		40901.3	40905.3	40905.1	40905.2	40905.4
<b>KARTELL BY LAUFEN</b>						
 <b>81233.1</b> 16 9/16" x 16 9/16" (420x420 mm)	●	●	●	●	●	●
 <b>81233.2</b> 29 8/16" x 13 12/16" (750x350 mm)	●	●	●	●	●	
<b>LIVING SQUARE</b>						
 <b>81143.3</b> 14 3/16" x 14 3/16" (360x360 mm)	●	●	●	●	●	●
 <b>81143.4</b> 23 10/16" x 13 6/16" (600x340 mm)	●	●	●	●	●	
 <b>81143.5</b> 14 15/16" x 14 15/16" (380x380 mm)	●	●	●	●	●	●
<b>PALOMBA COLLECTION</b>						
 <b>81680.1</b> 35 7/16" x 16 9/16" (900x420 mm)	●	●	●	●	●	
 <b>81680.2</b> 20 8/16" x 14 15/16" (520x380 mm)	●	●	●	●	●	●
 <b>81680.3</b> 23 10/16" x 15 12/16" (600x400 mm)	●	●	●	●	●	
<b>VAL</b>						
 <b>81228.1</b> 19 11/16" x 15 12/16" (500x400 mm)	●	●	●	●	●	●
 <b>81228.2</b> 21 10/16" x x 14 3/16" (550x360 mm)	●	●	●	●	●	●
 <b>81728.1</b> 21 10/16" x 14 3/16" (550x360 mm)	●	●	●	●	●	●
<b>INO</b>						
 <b>81230.0</b> 13 12/16" x 14 3/16" (350x360 mm)	●	●	●	●	●	●
 <b>81230.2</b> 19 11/16" x 14 3/16" (500x360 mm)	●	●	●	●	●	●
 <b>81730.1</b> 13 12/16" x 14 6/16" (350x365 mm)	●	●	●	●	●	●
 <b>81730.2</b> 19 11/16" x 14 6/16" (500x365 mm)	●	●	●	●	●	●

 <b>19 11/16"</b> <b>(500 mm)</b>	<b>35 7/16" (900 mm)</b>  <b>40900.3</b>	<b>47 4/16" (1200 mm)</b>  <b>40903.3</b>	<b>47 4/16" (1200 mm)</b>  <b>40903.1</b>	<b>47 4/16" (1200 mm)</b>  <b>40903.2</b>	<b>47 4/16" (1200 mm)</b>  <b>40903.4</b>
<b>KARTELL BY LAUFEN</b>  <b>1533.1</b> 18 2/16" x 18 2/16" (460x460 mm)  <b>1033.4</b> 23 10/16" x 18 2/16" (600x460 mm)  <b>1033.5</b> 23 10/16" x 18 2/16" (600x460 mm)  <b>1033.8</b> 35 7/16" x 18 2/16" (900x460 mm)  <b>1033.9</b> 35 7/16" x 18 2/16" (900x460 mm)  <b>1333.2</b> 47 4/1" x 18 2/16" (1200x460 mm)	<p>●</p> <p>●</p> <p>●</p> <p>●</p> <p>●</p> <p>●</p>	<p>●</p> <p>●</p> <p>●</p> <p>●</p> <p>●</p> <p>●</p>	<p>●</p> <p>●</p> <p>●</p> <p>●</p> <p>●</p> <p>●</p>	<p>●</p> <p>●</p> <p>●</p> <p>●</p> <p>●</p> <p>●</p>	<p>●</p>
<b>VAL</b>  <b>1628.0</b> 17 11/16" x 16 9/16" (450x420 mm)  <b>1628.2</b> 21 10/16" x 16 9/16" (550x420 mm)  <b>1628.3</b> 23 10/16" x 16 9/16" (600x420 mm)  <b>1628.4</b> 25 9/16" x 16 9/16" (650x420 mm)  <b>1628.5</b> 29 8/16" x 16 9/16" (750x420 mm)  <b>1628.7</b> 37 6/16" x 16 9/16" (950x420 mm)	<p>●</p> <p>●</p> <p>●</p> <p>●</p> <p>●</p> <p>●</p>	<p>●</p> <p>●</p> <p>●</p> <p>●</p> <p>●</p> <p>●</p>	<p>●</p> <p>●</p> <p>●</p> <p>●</p> <p>●</p> <p>●</p>	<p>●</p> <p>●</p> <p>●</p> <p>●</p> <p>●</p> <p>●</p>	<p>●</p> <p>●</p>
<b>INO</b>  <b>1630.0</b> 17 11/16" x 16 2/16" 450x410 mm  <b>1630.2</b> 22 1/16" x 17 11/16" (560x450 mm)	<p>●</p> <p>●</p>	<p>●</p> <p>●</p>	<p>●</p> <p>●</p>	<p>●</p> <p>●</p>	<p>●</p> <p>●</p>



# KARTELL BY LAUFEN



Contemporary bathrooms with clear lines and sensual colours are ideal for promoting a sense of well-being. Much bathroom activity centres around the plumbing fittings, so a lot is expected of them in terms of modern design, functionality, and hygiene.



# CERAMIC SHELVES AND ACCESSORIES



Lb3 and il Bagno Alessi One accessories make everyday routines easier. With the help of these useful little details you have everything within reach, neatly placed and easy to find. They not only help organise your bathroom, but also your mind – thus giving you the space you need to concentrate on the essentials.



# PRODUCT FEATURES AND BENEFITS: SANITARY WARE

## **Sanitary ware production: Tradition and innovation**

The basic ingredients for making ceramics have always been naturally occurring raw materials: Kaolinite, clay, feldspar and quartz sand form the basis for this extremely durable and hard material. The individual components of this malleable material are combined, homogenised and cleaned as part of a unique and very protracted process at LAUFEN. The resulting slurry – the pourable starting material for ceramics – is poured into pre-prepared plaster moulds or shaped using a special pouring process developed at LAUFEN.

The formability and pourability of the material allows the creation of a wide variety of sanitary ware products, but nevertheless always poses a manufacturing challenge, especially when creating objects with complex geometries. Dried and glazed blanks are then baked in a kiln at temperatures up to 1240°C. Such extreme kiln temperatures ensure the hardness and durability of our high-quality LAUFEN products.

Ceramics, through their smooth, easy-to-clean surface, fulfil the highest hygiene standards – chemical acids, strong cleaning fluids or hydrochloric compounds hardly affect the material. Due its light fastness, versatility and pleasant appearance, ceramic is the most popular material used to manufacture high-quality sanitary fittings.





**Top recycling qualities:** Ceramic is the oldest malleable material used by mankind – and consists exclusively of naturally occurring raw materials. Ceramic is 100% recyclable and can be reintroduced into production processes as a ground powder or reused as a valuable raw material in other industries.



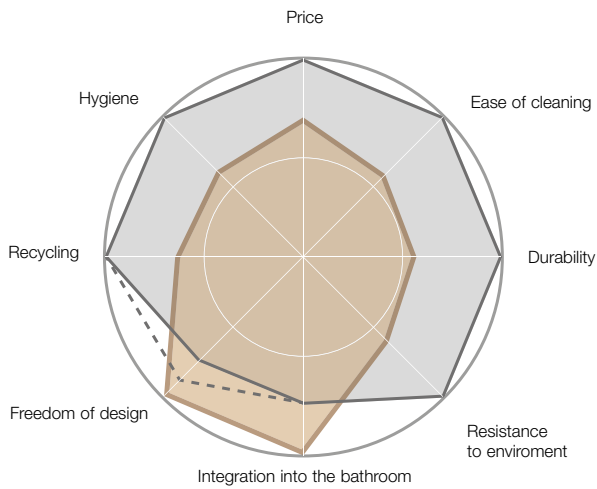



-  Sanitary ceramics
-  Mineral/Synthetic material
-  SaphirKeramik

**Ceramics or synthetic materials:** Ceramic is the material which has been traditionally used in the bathroom over the centuries – and with good reason. The superiority of the material is evident, particularly in terms of hygiene, useful lifetime, environmental compatibility and durability. However, washbasins made of plastics and mineral-based cast materials are also available on the market, which present a design challenge to producers of sanitary ware. LAUFEN has always had a reputation as an innovator in the sanitary sector and is always striving to improve the materials and production techniques it uses. As a result of these efforts, new ceramic compositions have been developed that allow smaller tolerances and even more precise corner radii or large flat ceramic items. Made to measure washbasin solutions ensure that ceramic sanitary ware can be fitted with millimetre precision into bathroom floor plans. Ceramics therefore deliver outstanding performance in all respects.



**A revolution in the formal language of ceramics:**

The innovative and high-quality composition of SaphirKeramik bestows possibilities and versatility never seen before upon the base material, enabling exceptional shaping. Edge radii of 1/16" (1–2 mm) are thus technically feasible. The new type of ceramic is considerably harder and has an improved bending strength. LAUFEN is thus able to produce thinner ceramic bodies, which reduces weight and the consumption of raw materials and energy. SaphirKeramik is not a replacement for any of the existing materials; instead, it broadens the range of forms of expression of the natural base material.

 SaphirKeramik

# PRODUCT FEATURES AND BENEFITS: SANITARY WARE

LCC stands for **Laufen Clean Coat**. This innovative ceramic surface finish is a vitreous silicate ceramic coating which is fired on top of the original glaze. LCC is an extremely hard, indeed almost indestructible indivisible part of the ceramic object to which it is applied.

The benefits of this process: With a roughness of only 4 nanometers, LCC is entirely free of pores. Thanks to this feature, lime, dirt and bacteria have practically nowhere to gain a foothold – and even if they do, they can be removed much more easily. A hydrophilic effect caused by the material ensures that dirt particles are more easily washed away on flushing. In addition, cleaning and disinfection fluids spread over the surface more easily and thus work more effectively. This is an ideal solution for the rigorous demands of everyday cleaning – for example in hotels or clinics – as LCC also means the sanitary ware is highly resistant to aggressive cleaning agents and chemicals. LCC ensures the highest standard of cleanliness and hygiene in the long-term. Even after years of use, the sanitary ware remains smooth and shiny, just as it was when it was brand new, in private bathrooms and public and semi-public areas.

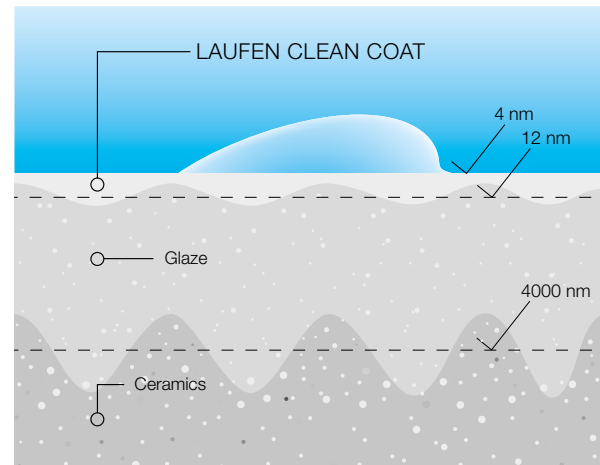

The innovative glaze for durable hygiene.



Our **concealed ceramic overflow system**, the alternative to standard overflows for selected washbasins and bidets, has many benefits. Thanks to our overflow system which is invisible from the outside, our washbasins and bidets no longer have a visible overflow hole, which not only improves the appearance of the product, it also makes cleaning much easier. This hygienic and aesthetic innovation is very simple: water rises in a concealed internal channel in parallel with the water inside the washbasin, and overflows into the runoff when the water reaches the maximum level.





LAUFEN is breaking the mould when it comes to **drain design**. The new washbasins in the Kartell by LAUFEN range have no visible drainage opening. The water disappears into a narrow, hidden drain through an elegant pipe. A concealed overflow system has also been developed. A special valve allows you to choose between a solution which is always open or which can be closed off.



**LAUFEN EasyFit:** LAUFEN has developed a revolutionary wall fixation system for WCs, bidets and urinals. A patent has been lodged. The invisible, easy to mount fixation system meets the needs of both fitters and end users. For example, end users are impressed by a ceramic WC with a flawless surface which is really easy to clean since there's nowhere for dirt to hide. Fitters are enthusiastic about the time-saving, intuitive mounting system.



Thanks to our convenient **lowering system** many of our WC covers and seats close gently and quietly. For easier cleaning, all LAUFEN seats can be removed with a simple hand movement. LAUFEN seats have been comprehensively tested: amongst others the test includes opening and closing 50,000 times.



# PRODUCT FEATURES AND BENEFITS: SANITARY WARE

The installation dimensions of WCs are not always identical: In many renovation situations the LAUFEN **Vario outlet** can make it easier to connect the WC to the sewage network.



Drain adapter for vertical floor outlet



Drain adapter for horizontal wall outlet

Water from the rear water outlet transports the material to be flushed away to the siphon

The entire basin is flushed and cleaned over all of the flush apertures around the ring

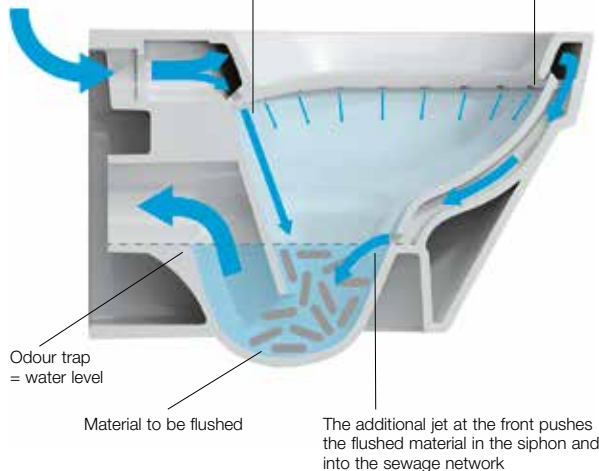

**HiJet WC:** A new type of WC having highest-performance flushes with volumes of 4.5 and 6 litres. This unique model unites all worldwide standards. Maximum performance tests have shown that this powerful WC is prepared to meet future standards. It does already achieve outstanding flushing results with 2–3 litres, if the downstream drainage systems are designed for this purpose. LAUFEN has lodged a patent for this new flushing system.



0L



The **LAUFEN lema** 0-litre urinal saves water and money. It operates without water and does not require a water shut-off device or electricity to keep the drain closed. The urine itself helps to keep gases sealed in and to prevent their escape. The principle behind this “trap” is known in the chemical industry as the Erlenmeyer flask.



The **intelligent control system** has different modes and can trigger cleaning after each user or at defined intervals with different flush quantities of between 0.5 and 3 litres. Following long periods of non-use, a hygiene flush takes place every 24 hours by default. There is also an integrated overflow protection function in case the drain hole becomes blocked.

#### Hybrid mode

The urinal flushes at a predefined interval if usage is detected, and not after every single use. The flushing interval can be set to six different values between 1 h and 12 h. A predefined flushing volume is assigned to each flushing interval.



**Made-to-measure sanitary ware:** Many large LAUFEN washbasins can be manufactured made-to-measure at the factory. Using this innovative production technology, we can manufacture sanitary ware to fit the plan of your bathroom. On the one hand, the ceramic can be cut to size – even on the diagonal. On the other, even freestanding side elements can be custom made without any visible side panel attachments.

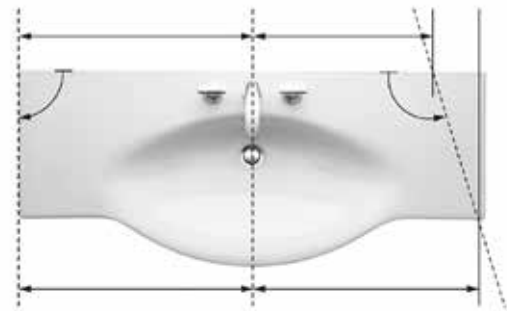

The bathroom is private. So that it stays that way, LAUFEN provides **sound insulation sets**, consisting of specialised foam and rubber elements for its washbasins and wall-mounted WCs. These elements considerably reduce the amount of noise due to usage and functions that passes through the wall into neighbouring rooms.

Depending on the structural situation, a sound reduction of up to 9 decibels can be achieved, which means that noise is reduced by almost half.

These sets have been tested against SIA 181 and DIN 4109 and certified by Fraunhofer.

- 89269.1 sound insulation set for washbasins up to 80 cm
- 89269.2 sound insulation set for washbasins of 80–100 cm
- 89269.3 sound insulation set for washbasins of 110–180 cm
- 89269.4 sound insulation set for WC



# PRODUCT FEATURES AND BENEFITS: FURNITURE, LIGHTS AND MIRRORS

**Furniture surfaces** in the bathroom are designed to deal with the room's special climate conditions. LAUFEN provides a range of different surfaces, all optimised for their intended use and come with a guaranteed long useful life.

## **Real wood veneer:**

A cosy bathroom in wood. The classy wood veneers provide the haptics and optics of real wood. They are resistant to moisture and equipped with reinforced edges, making them resistant to impacts. These real wood veneers include those used in Lb3 and ILBAGNOALESSI One 'noce canal-etto'.

## **Film coatings:**

Film coatings are pulled over corners, thus ensuring the furniture surfaces are joint-free and not sensitive to water. They are scratch, water and light-resistant. Their flexibility offers a great deal of design freedom in terms of the forms used, such as integrated handles, for example. LAUFEN uses film coatings in its LAUFEN pro, moderna plus and case ranges.

## **Painted furniture surfaces:**

Our classic high-gloss paint finish, using two-component water-resistant paints, offers perfect surfaces with no unevenness and a wide range of colours. LAUFEN painted surfaces include the ILBAGNOALESSI One white furniture and LAUFEN also offers 38 additional special paints (shown on right) for the case and LAUFEN pro furniture ranges.

**Tidy storage systems** in drawers of the ILBAGNOALESSI One bathroom furniture range ensure tidy storage and prevent the return of chaos every time a drawer is closed fast.





Slamming of doors is not inevitable: At LAUFEN, **soft close** means gently-closing furniture doors and drawers. The system is integrated as standard into all LAUFEN furniture. In this case, quality can be felt and not heard.



Comfort in every detail: The flexible and adjustable **3D mounting system** makes installation LAUFEN furniture on the wall quick and easy.



LAUFEN undercounter furniture is exclusively equipped with an innovative **space-saving siphon** (1). This dispenses with the need for siphon cut-outs in the drawers (2), reclaims valuable storage space and ensures unlimited use of internal space.

# OVERVIEW OF CERAMIC COLOURS

## ILBAGNOALESSI ONE

 **.400** white LCC (Laufen Clean Coat)

## ILBAGNOALESSI DOT

 **.400** white LCC (Laufen Clean Coat)

## PALOMBA COLLECTION

 **.000** white

 **.400** white LCC (Laufen Clean Coat)

## KARTELL BY LAUFEN

 **.000** white

 **.400** white LCC (Laufen Clean Coat)

 **.757** white matt\*

 **.020** black glossy\*

 **.759** grey matt\*

## LIVING CITY / LIVING SQUARE

 **.000** white

 **.400** white LCC (Laufen Clean Coat)

## LB3

 **.000** white

 **.400** white LCC (Laufen Clean Coat)

## INO

 **.000** white

 **.400** white LCC (Laufen Clean Coat)

## VAL

 **.000** white

 **.400** white LCC (Laufen Clean Coat)

## PALACE

 **.000** white

 **.400** white LCC (Laufen Clean Coat)

## LAUFEN PRO

 **.000** white

 **.400** white LCC (Laufen Clean Coat)



It is possible that not all products, sizes or colours are available in every country. The price list of your LAUFEN/ROCA subsidiary is the most accurate reference point for product availability. Delivery periods may also differ.

The colours shown may not be absolutely identical to the actual colours. The bathroom environments shown here are simply decorative settings and do not take all technical requirements into consideration. The decoration schemes shown are not included in our range of products.

Printed on certified paper from sustainably managed forests.

With the publication of this catalogue, all previous documents are invalid. We reserve the right to change specifications without prior notice. We can provide you with the actual data on our website [www.laufen.com](http://www.laufen.com).

Design is copyright protected.

## Photography

### **ILBAGNOALESSI ONE**

Fabrizio Bergamo, Giuseppe Pino,  
Maurizio Marcato

### **ILBAGNOALESSI DOT**

Santi Caleca, Riccardo Bianchi

### **PALOMBA COLLECTION**

Adriano Brusaferrì, Max Majola,  
Carlo Ciraudò, Maurizio Marcato,  
Luca Fregoso, Max Zambelli

### **KARTELL BY LAUFEN**

Adriano Brusaferrì

### **LIVING**

Christoph Kern, Maurizio Marcato  
Studio Casa

### **LB3**

Max Zambelli, Maurizio Marcato

### **VAL**

Adriano Brusaferrì

### **INO**

Adriano Brusaferrì

### **PALACE**

Studio Casa

### **LAUFEN PRO**

Christoph Kern, Maurizio Marcato  
Studio Casa

### **CASE**

Andrea Pitari

### **SPACE**

Adriano Brusaferrì

### **BOUTIQUE**

Adriano Brusaferrì

### **ANTERO**

Adriano Brusaferrì



[www.laufen.com](http://www.laufen.com)



[www.tc.laufen.com](http://www.tc.laufen.com)



Laufen Bathrooms App for iPhone/iPad



[www.bim.laufen.com](http://www.bim.laufen.com)



[www.facebook.com/laufenbathrooms](http://www.facebook.com/laufenbathrooms)



[www.twitter.com/laufenbathrooms](http://www.twitter.com/laufenbathrooms)



[www.pinterest.com/laufenbathrooms](http://www.pinterest.com/laufenbathrooms)



[www.youtube.com/laufenbathrooms1](http://www.youtube.com/laufenbathrooms1)

LAUFEN  
Bathrooms North America  
Tel. + 1 866. 696. 2493  
Fax. +1 866. 628.1760  
[usa@laufen.com](mailto:usa@laufen.com)  
[canada@laufen.com](mailto:canada@laufen.com)  
[northamerica@laufen.com](mailto:northamerica@laufen.com)  
[www.us.laufen.com](http://www.us.laufen.com)

LAUFEN